

REVISIONS			
REV.	DESCRIPTION	DATE	APPROVED

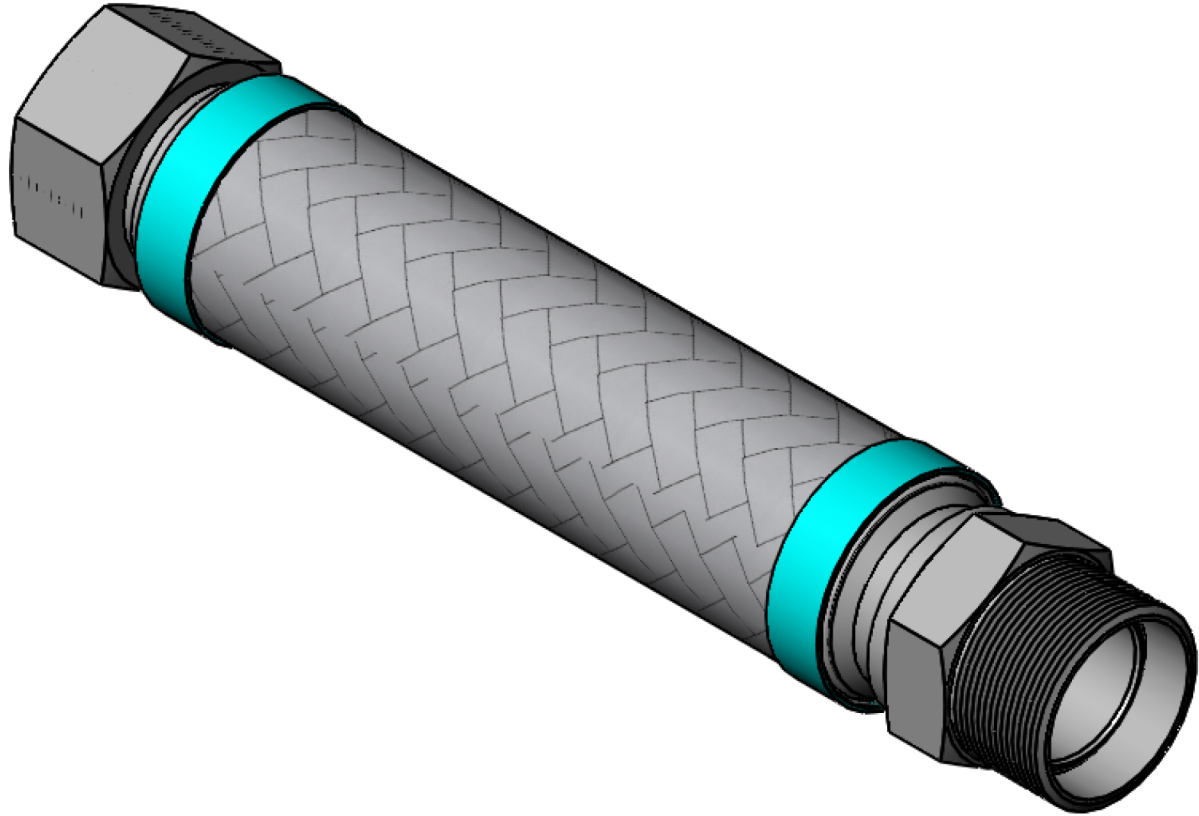
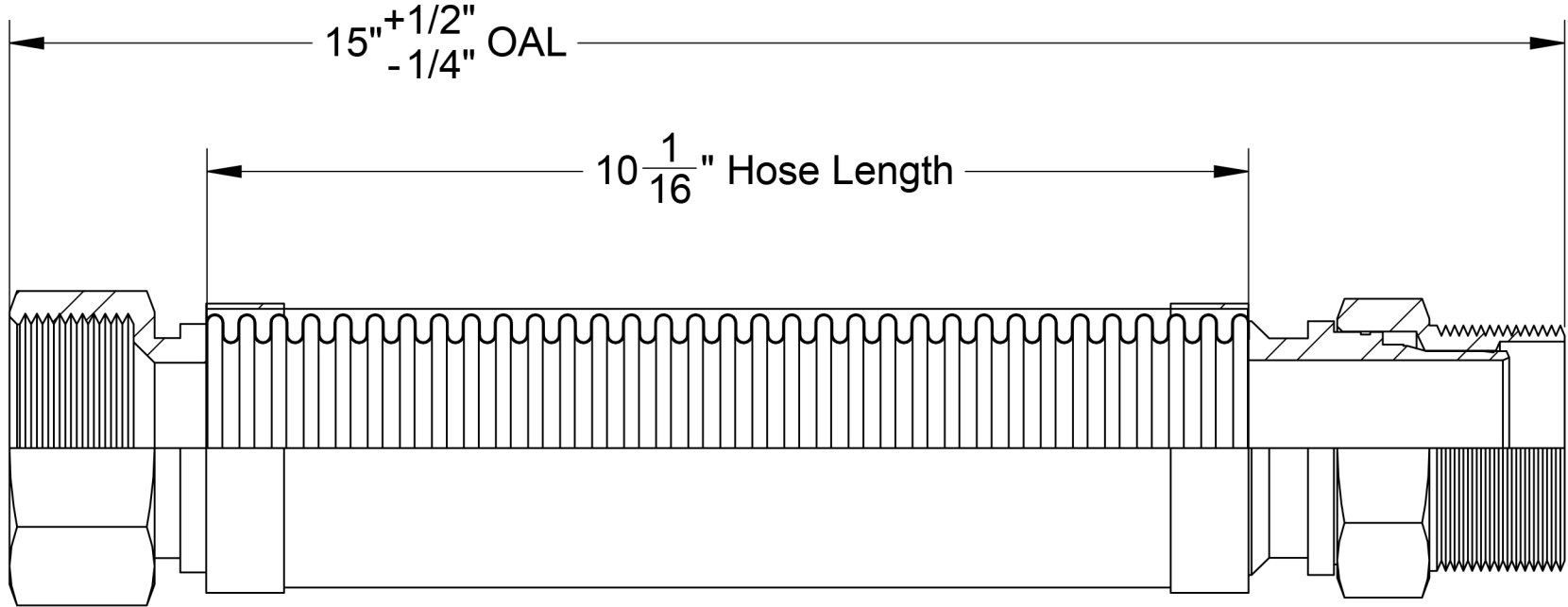

ITEM #	QTY.	PART NUMBER	DESCRIPTION	MATERIAL	WEIGHT
1	1	HOSE	300 Series Stainless HYDROFORMED Corrugated Hose	Stainless Steel	0.58
2	1	BRAID	300 Series Stainless Steel	Stainless Steel	0.05
3	2	BRAID COLLAR	0.05" Thick	Stainless Steel	0.09
4	1	2" FEMALE	2" Female, 2"x11-1/2" Thread, 2.38" Hex	Carbon Steel	0.83
5	1	2" MALE SWIVEL	2" Male Swivel, 2"x11-1/2" Thread, 2.38" Hex	Carbon Steel	0.93

	HOSE MASTER Inc. 1233 East 222nd Street • Cleveland, Ohio 44117 (800) 221-2319 • Fax: (216) 481-7557 • www.hosemaster.com Locations: Cleveland • Houston		Registered to: ISO 9001 : 2000

Projection:	Customer: Hose Master Inc.	Prepared By: kannk
	Reference: Fire-Shield - 2" Female x 2" Male Swivel x 15" OAL	CALC. WEIGHT: 3 lbs. Date: 9/24/2009

Description: **2" ID x 15" OAL 300 Series Stainless HYDROFORMED Corrugated Hose covered by 300 Series Stainless Braid. UL Approved 2" Female Connector x 2" Male Swivel Connector**

Drawing #:	FSFS0200x15	Rev.:	-	SHEET 1 OF 1
------------	--------------------	-------	---	--------------